



INDUSTRIAL MAGZA
DIST. AUTORIZADO

MEX (55) 53 63 23 31 MTY (81) 83 54 10 18
QRO (442) 1 95 72 60 ventas@industrialmagza.com

nexen

AIR CHAMP® PRODUCTS

User Manual

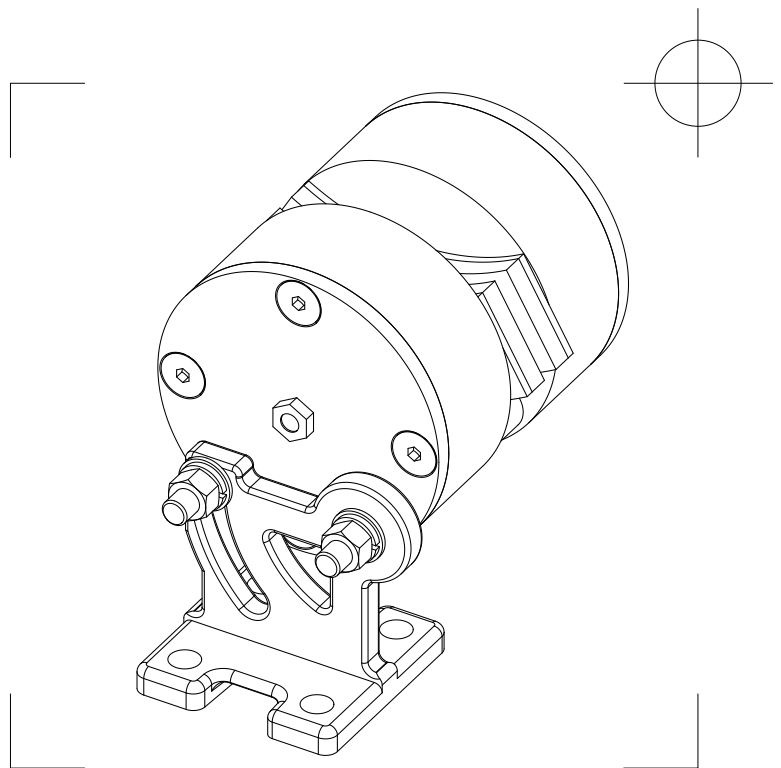

Disc Caliper Brake Model DBSE



INDUSTRIAL MAGZA
DIST. AUTORIZADO

MEX (55) 53 63 23 31 MTY (81) 83 54 10 18
QRO (442) 1 95 72 60 ventas@industrialmagza.com

In accordance with Nexen's established policy of constant product improvement, the specifications contained in this manual are subject to change without notice. Technical data listed in this manual are based on the latest information available at the time of printing and are also subject to change without notice.

Technical Support:
800-843-7445
651-484-5900

www.nexengroup.com



WARNING

Read this manual carefully before installation and operation.

Follow Nexen's instructions and integrate this unit into your system with care.

This unit should be installed, operated and maintained by qualified personnel **ONLY**.

Improper installation can damage your system or cause injury or death.

Comply with all applicable codes.

Nexen Group, Inc.
560 Oak Grove Parkway
Vadnais Heights, Minnesota 55127

Table of Contents

Installation	1
Lubrication	3
Manual Disengagement	3
Friction Facing Replacement	4
Seal Replacement	5
Troubleshooting	6
Parts List	7
Warranty	8



INSTALLATION

NOTE: The Brake Disc (ordered separately) may be mounted to a customer supplied hub or mounted to the Nexen Disc Brake Hub (also ordered separately) for use with a Q.D. Bushing.

1. Apply a drop of Loctite® 242 to the threads of the six Flat Head Hex Socket Cap Screws provided with the Brake Disc and secure the Brake Disc to the Brake Disc Hub or to a customer-supplied hub (See Figure 1).
2. Alternately and evenly tighten the six Flat Head Hex Socket Cap Screws to the recommended torque (See Figure 1 and Table 1).
3. Thoroughly inspect the tapered bore of the Brake Disc Hub and the tapered surface of the Q. D. Bushing. Remove any dirt, grease, or foreign material. Do not use lubricants for this installation.
4. Assemble the Q.D. Busing into the Brake Disc Hub, aligning the untapped holes in the Q.D. bushing with the tapped holes in the Brake Disc Hub.

NOTE: Runout is minimized if a Dial Indicator is used as the pull-up bolts are tightened. Place the contact tip of the Dial Indicator on the machined surface of the Brake Disc to measure runout. Runout should be less than 0.010-0.015 in. [.0254-0.381 mm.] (See Figure 2).

CAUTION

If excessive tightening torque is applied, bursting pressures are created in the Brake Hub. There must be a gap between the flange of the Q.D Bushing and the Brake Disk to ensure a proper fit of the Q.D. Bushing onto the shaft

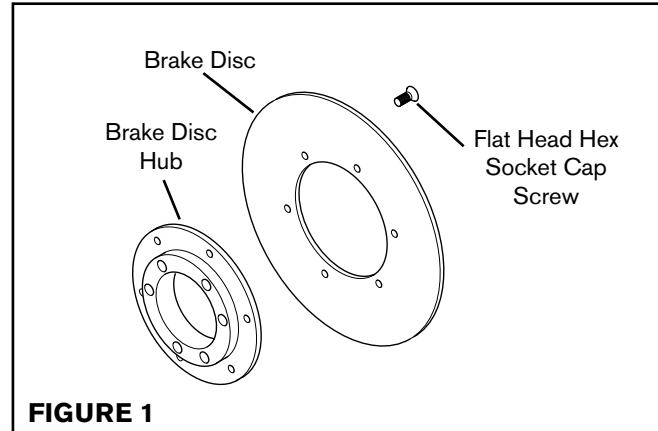

FIGURE 1

TABLE 1

RECOMMENDED TIGHTENING TORQUES FLAT HEAD HEX SOCKET CAP SCREWS	
MODEL	TORQUE
10 in. Disc (Prod. No. 855500)	45 in-lb (5.04 Nm)
12 in. Disc (Prod. No. 855600)	105 in-lb (11.76 Nm)
14 in. Disc (Prod. No. 855700)	105 in-lb (11.76 Nm)
16 in. Disc (Prod. No. 855800)	105 in-lb (11.76 Nm)

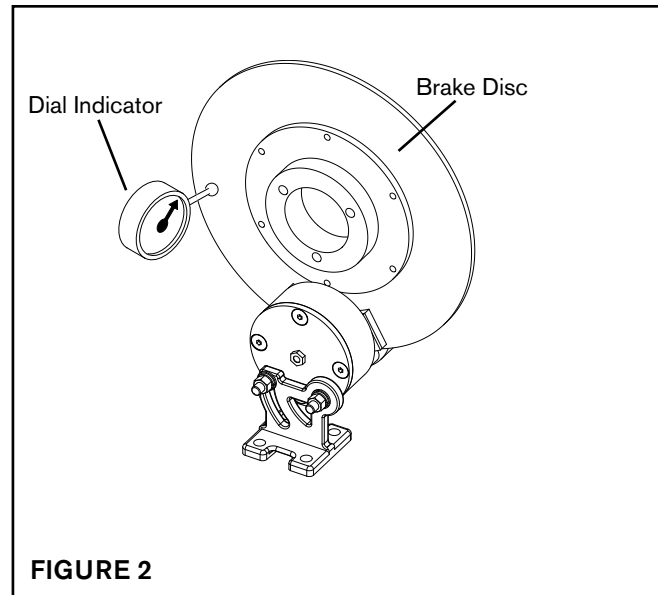
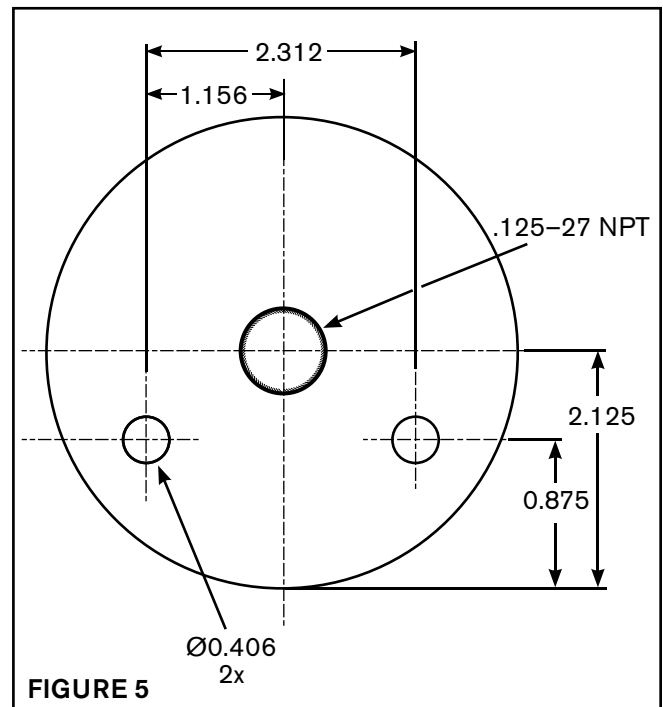
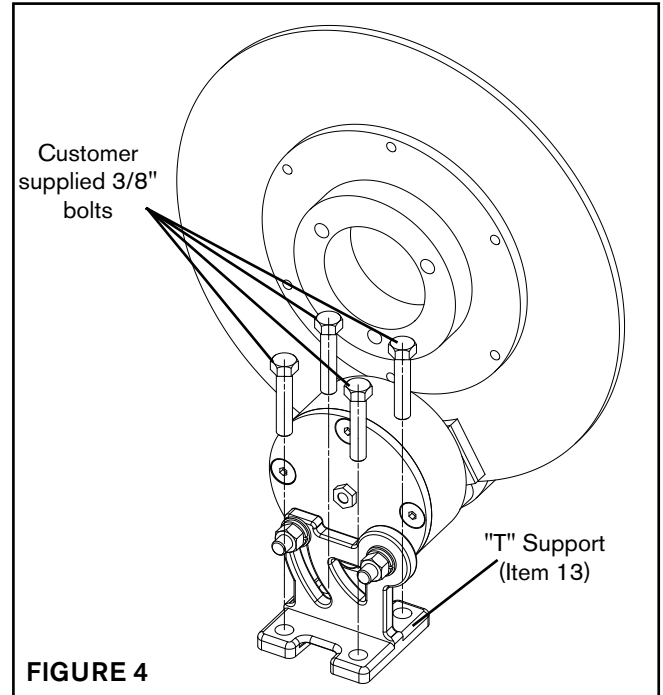
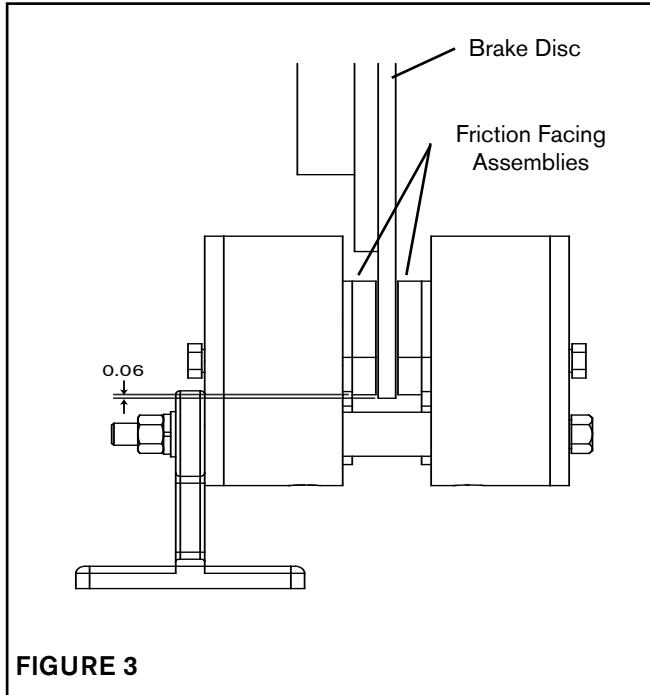

FIGURE 2

5. Insert the pull-up bolts and alternately and evenly tighten them to 15 ft-lb [20.3 Nm] torque.
6. To remove the Q.D. Bushing, remove the pull-up bolts and reinsert them into the threaded holes of the Q.D. Bushing. Tighten the pull-up bolts to push out the Q.D. Bushing.
7. Mount the Caliper Brake so the radius of the Disc runs approximately 0.06 in [1.6 mm] below the outside radius of the Friction Facing Assembly (Item 1), and with an equal distance between the Disc and Friction Facing Assemblies (See Figure 3).
8. Use customer-supplied 3/8 in. bolts to mount the "T" support (Item 12) to a solid base (See Figures 3 and 4).
9. The Caliper Brake can be flush-mounted. The 3/8-16 mounting bolts can secure the Caliper Brake to a solid mounting surface. The recommended mounting hole pattern includes a .125-27 NPT thread to relocate the breather fitting and allow access for manual disengagement (See Figure 5).





LUBRICATION

NOTE: Pneumatically actuated devices requires clean, pressure regulated, and lubricated air for maximum performance and long life. The most effective and economical way to lubricate Nexen Clutches and Brakes is with an Air Line Lubricator, which injects oil into the pressurized air, forcing an oil mist into the air chamber.

Locate the lubricator above and within ten feet of the clutch or Brake, and use a low viscosity oil such as sae-10.

Synthetic lubricants are not recommended.

LUBRICATOR DRIP RATE SETTINGS

NOTE: These setting are for Nexen supplied lubricators. If you are not using a Nexen lubricator, calibration must replicate the following procedure.

1. Close and disconnect the air line from the unit.
2. Turn the lubricator Adjustment Knob clockwise three complete turns.
3. Open the air line.
4. Close the air line to the unit when a drop of oil forms in the lubricator Sight Gage.
5. Connect the air line to the unit.
6. Turn the Lubricator Adjustment Knob counterclockwise until closed
7. Turn the Lubricator Adjustment Knob clockwise one-third turn.
8. Open the air line to the unit.

MANUAL DISENGAGEMENT

For manual disengagement of the brake, remove the breather fittings. Insert a 5/16-18 x 1 1/2 bolt or cap screw through the breather port. Screw into the piston until the caliper brake is disengaged.



FRICITION FACING REPLACEMENT

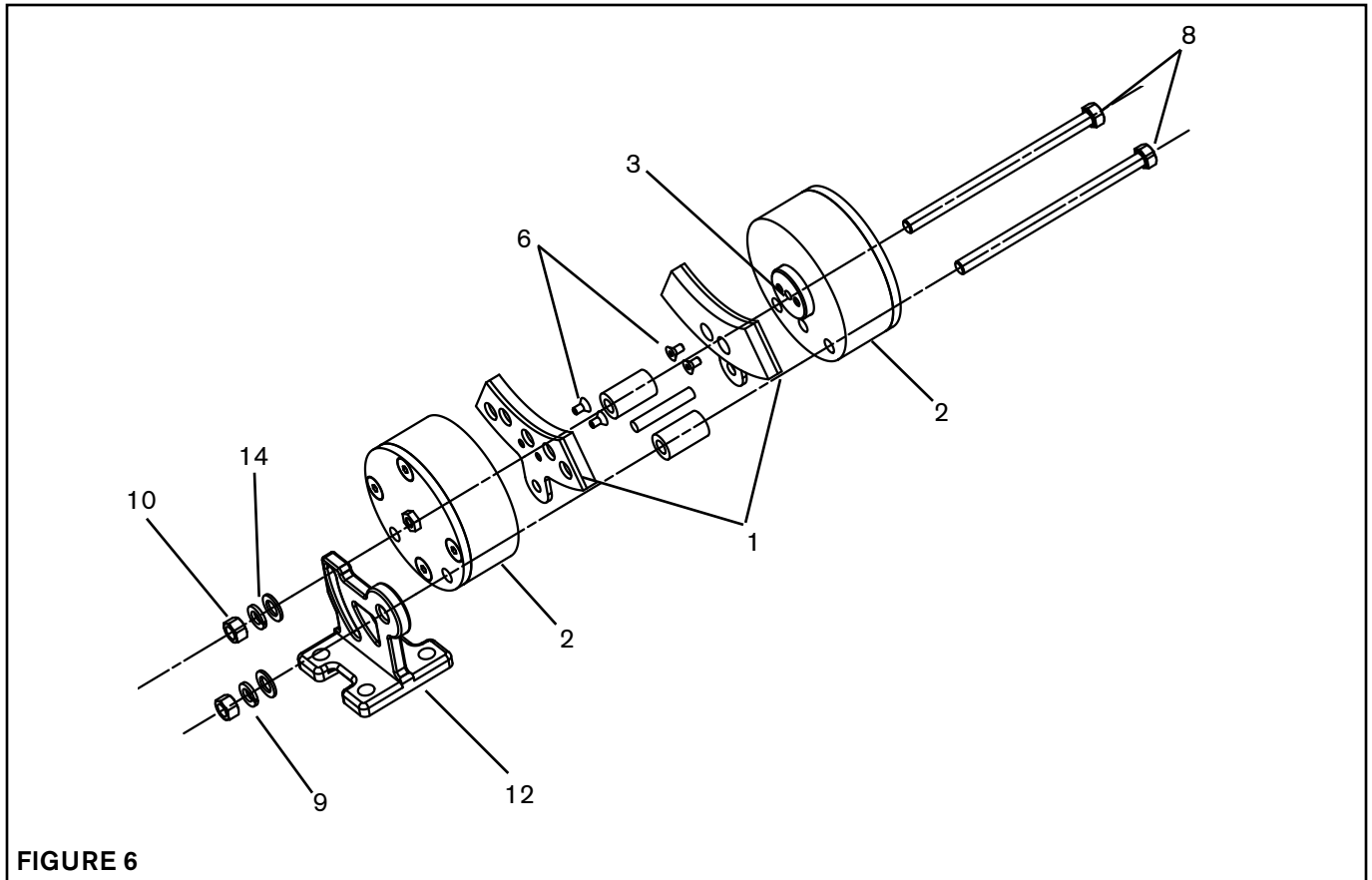

FIGURE 6

1. Remove the two Hex Head Screws (Item 8), Hex Head Nuts (Item 10), Lock Washers (Item 9), and Flat Washers (Item 14). Then remove the two Cylinders (Item 2) from the "T" Support (Item 12) (See Figure 6).
2. Separate the two Cylinders (Item 2) (See Figure 6).
3. Remove the Flat Head Cap Screws (Item 6) securing the old Friction Facing Assemblies (Item 1) to the Piston (Item 3) (See Figure 6 & 9).
4. Apply Loctite® 242 to the threads of the Flat Head Screws (Item 6); then secure the new Friction Facing Assemblies (Item 1) to the Pistons (Item 3) (See Figure 6 & 9).
5. Tighten the Flat Head Cap Screws to 37–48 in-lb (4.2–5.4 Nm).
6. Using the two Hex Head Screws (Item 8), Hex Nuts (Item 10), Lock Washers (Item 9), and Flat Washers (Item 14), secure the two Cylinders (Item 2) to the "T" Support (Item 12) (See Figure 6).



SEAL REPLACEMENT

1. Remove the two Hex Head Cap Screws (Item 8), Hex Head Nuts (Item 10), Lockwashers (Item 9) and Flat Washers (Item 14). Then remove the two Cylinder Assemblies (Item 2) from the "T" Support (Item 12). (See Figure 6).
2. Separate the two Cylinder Assemblies (Item 2) and set the Spacers (Item 13) and Pin (Item 4) aside. (See Figure 6 & 9).
3. Remove the Flat Head Cap Screws (Item 6) securing the Shoe Facings (Item 1) to the Piston (Item 3). (See Figure 7 & 9).

7. Clean the O-Ring grooves of the Pistons (Item 3); then, lubricate the new U-Cup Seals and O-Rings and contact surfaces with a thin film of fresh o-ring lubricant.
8. Install the new U-Cup Seals (Item 5) and O-Rings (Item 15) onto both Pistons (Item 3).

Note: Orientation of U-Cup Seal is important. Open side of U-Cup Seal should face into the Cylinder (Item 2). (See Figure 7).

9. Place Springs (Item 11) into spring pockets of Pistons (Item 3).

10. Attach End Caps (Item 16) to Cylinders (Item 2) with Flat Head Cap Screws (Item 17).

Note: Orientation of mounting holes in End Cap must match mounting holes in Cylinder. Alternately and evenly tighten Flat Head Cap Screws to 178–232 in-lbs (20.1–26.2 Nm).

11. Apply Loctite 242 to the threads of the Flat Head Cap Screws (Item 6); then secure the Friction Facings (Item 1) to the Pistons (Item 3). Tighten Flat Head Cap Screws to 37–48 in-lbs (4.2–5.4 Nm).

4. Remove the Flat Head Cap Screws (Item 17), End Cap (Item 16) and Springs (Item 11) from both Cylinders (item 2). (See Figure 7).
5. Push Pistons (Item 3) out of both Cylinders (Item 2). (See Figure 7).
6. Remove old U-Cup Seals (Item 5) and O-Rings (Item 15) from both Pistons (item 3). (See Figure 7).

12. Using the two Hex Head Cap Screws (Item 8), Hex Nuts (Item 10), Lock Washers (Item 9) and Flat Washers (Item 14), secure the two Cylinder assemblies (Item 2) with the Spacers (Item 13) and Pin (Item 4) to the "T" support (Item 12).



WARNING

End Cap is spring loaded. End Cap and Cylinder can spring apart, resulting in personal injury if End Cap and Cylinder are not clamped together.

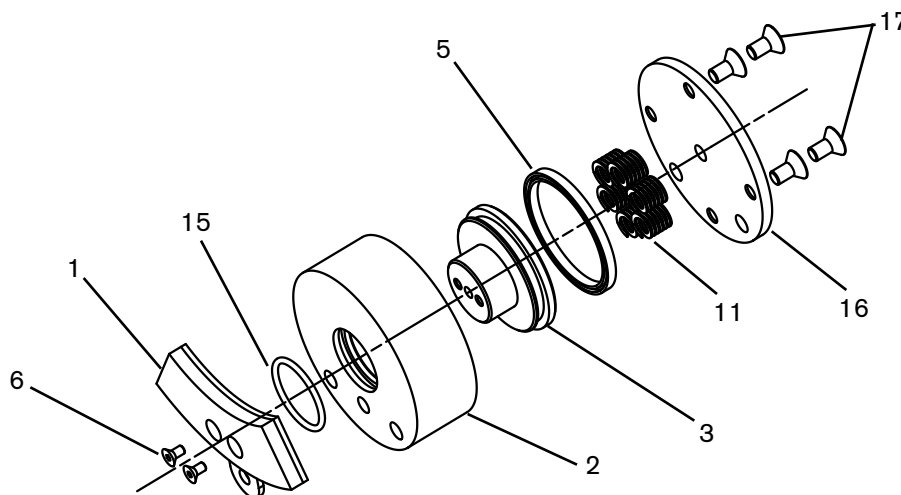

FIGURE 7



TROUBLESHOOTING

Symptom	Probable Cause	Solution
Failure to engage	Air not being exhausted due to a control valve malfunction.	Replace the control valve.
	Broken compression spring	Replace the compression springs.
	Internal contamination or corrosion.	Align the exhaust port to the six-o'clock down position to allow condensation to drain out of the exhaust port.
Failure to disengage	Los or lack of air pressure.	Check for control valve malfunction and replace it if necessary. Check for air leaks in the air lines and around the o-ring seals. Replace the air lines or o-ring seals if necessary.
	Internal contamination or corrosion.	Align the exhaust port to the six-o'clock down position to allow condensation to drain out of the exhaust port.
Loss of torque	Worn or dirty Facings.	Replace Friction Facings.

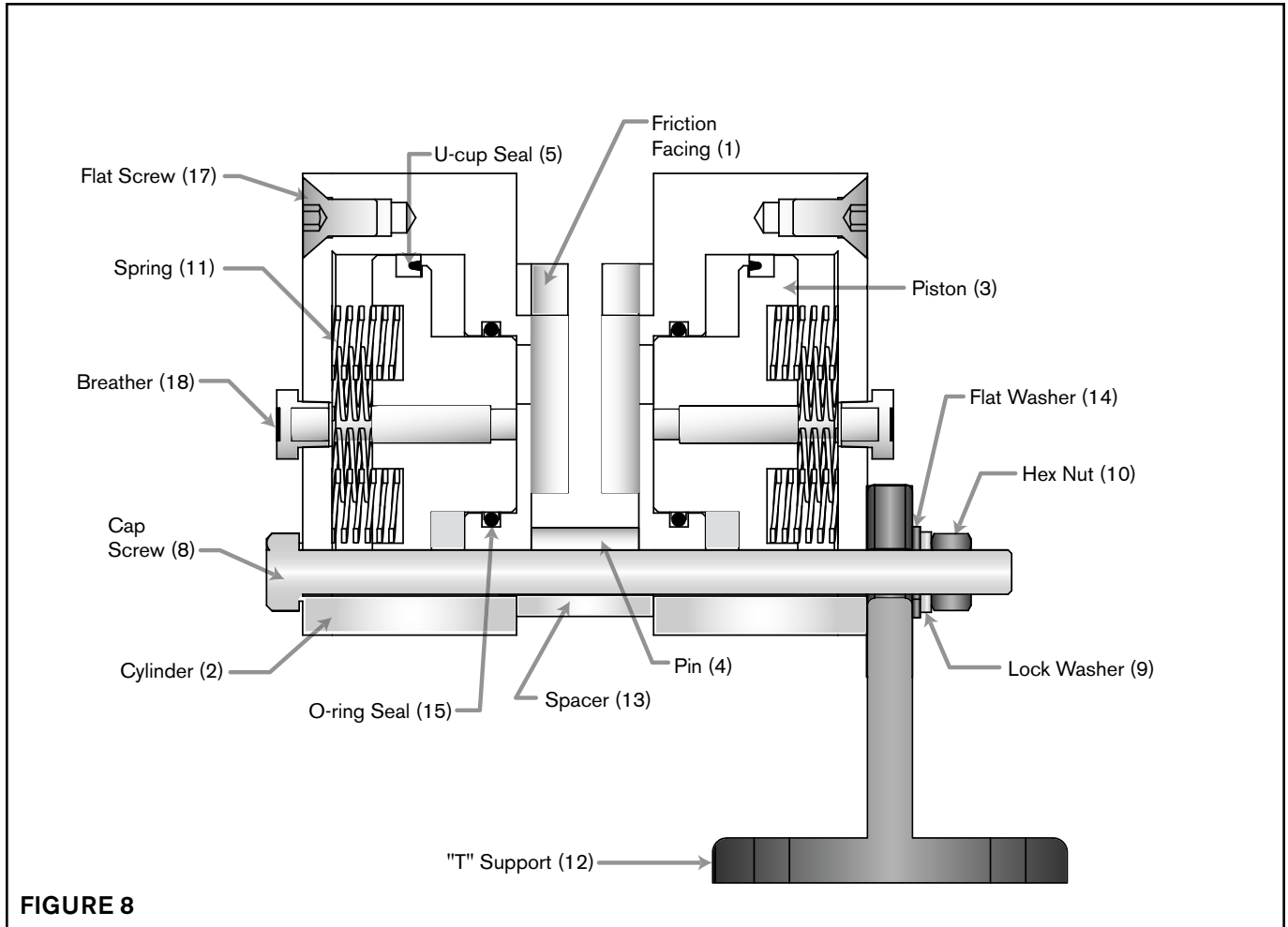

FIGURE 8

PARTS LIST

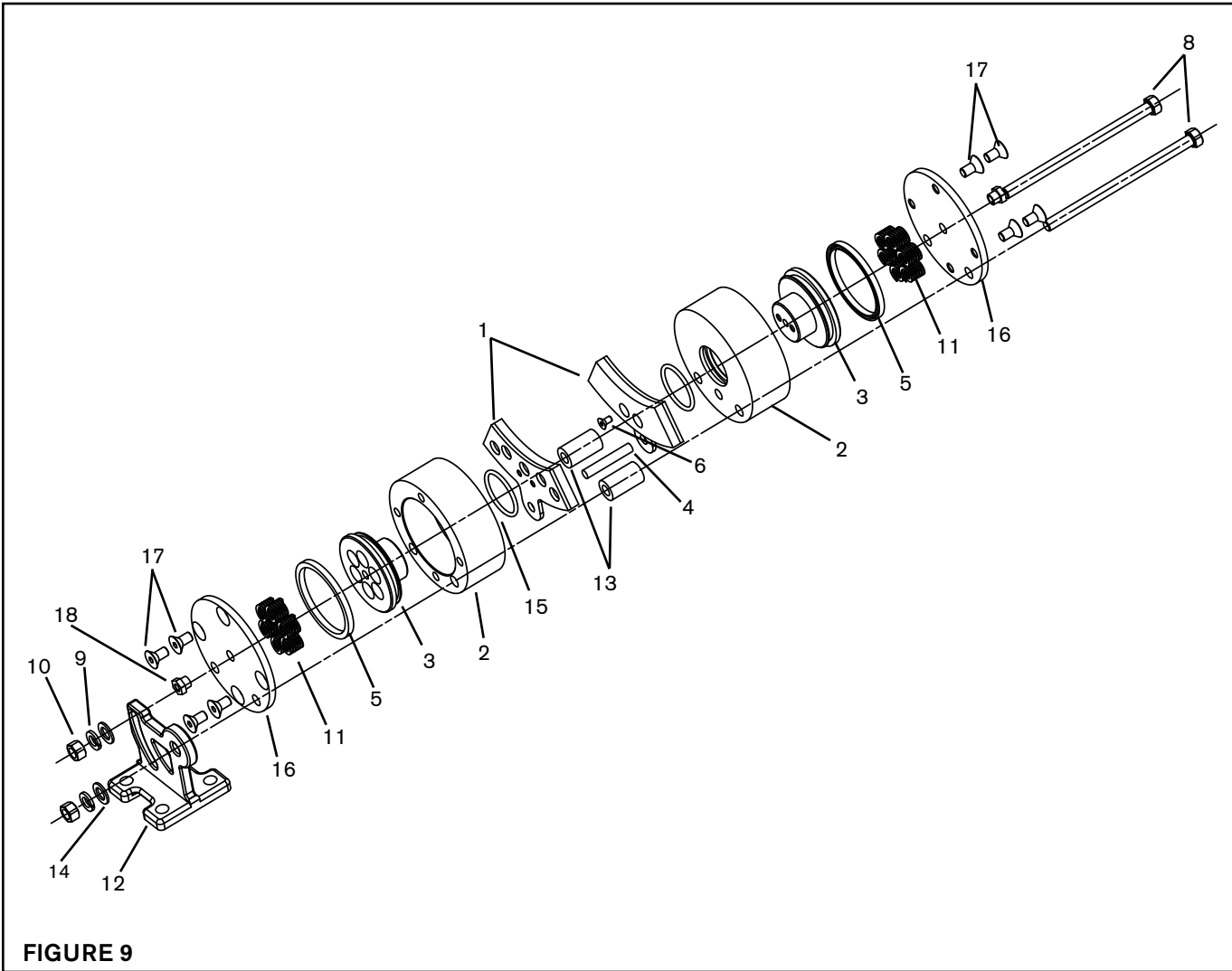

FIGURE 9

ITEM	DESCRIPTION	QTY
1	Friction Facing Assembly	2
2	Cylinder	2
3	Piston	2
4	Pin	1
5	U-Cup Seal	2
6	Cap Screw	4
8	Hex. Head Screw	2
9	Lock Washer	2
10	Hex. Nut	2

ITEM	DESCRIPTION	QTY
11	Compression Spring	12*
12	"T" Support	1
13	Spacer	2
14	Flat Washer	2
15	O-Ring	2
16	End Cap	2
17	Flat Cap Screw	8
18	Breather Fitting Plug	2

* Varies by unit.



WARRANTY

Warranties

Nexen warrants that the Products will be free from any defects in material or workmanship for a period of 12 months from the date of shipment. NEXEN MAKES NO OTHER WARRANTY, EXPRESS OR IMPLIED, AND ALL IMPLIED WARRANTIES, INCLUDING WITHOUT LIMITATION, IMPLIED WARRANTIES OF MERCHANTABILITY AND FITNESS FOR A PARTICULAR PURPOSE ARE HEREBY DISCLAIMED. This warranty applies only if (a) the Product has been installed, used and maintained in accordance with any applicable Nexen installation or maintenance manual for the Product; (b) the alleged defect is not attributable to normal wear and tear; (c) the Product has not been altered, misused or used for purposes other than those for which it was intended; and (d) Buyer has given written notice of the alleged defect to Nexen, and delivered the allegedly defective Product to Nexen, within one year of the date of shipment.

Exclusive Remedy

The exclusive remedy of the Buyer for any breach of the warranties set out above will be, at the sole discretion of Nexen, a repair or replacement with new, serviceably used or reconditioned Product, or issuance of credit in the amount of the purchase price paid to Nexen by the Buyer for the Products.

Limitation of Nexen's Liability

TO THE EXTENT PERMITTED BY LAW NEXEN SHALL HAVE NO LIABILITY TO BUYER OR ANY OTHER PERSON FOR INCIDENTAL DAMAGES, SPECIAL DAMAGES, CONSEQUENTIAL DAMAGES OR OTHER DAMAGES OF ANY KIND OR NATURE WHATSOEVER, WHETHER ARISING OUT OF BREACH OF WARRANTY OR OTHER BREACH OF CONTRACT, NEGLIGENCE OR OTHER TORT, OR OTHERWISE, EVEN IF NEXEN SHALL HAVE BEEN ADVISED OF THE POSSIBILITY OR LIKELIHOOD OF SUCH POTENTIAL LOSS OR DAMAGE. For all of the purposes hereof, the term "consequential damages" shall include lost profits, penalties, delay images, liquidated damages or other damages and liabilities which Buyer shall be obligated to pay or which Buyer may incur based upon, related to or arising out of its contracts with its customers or other third parties. In no event shall Nexen be liable for any amount of damages in excess of amounts paid by Buyer for Products or services as to which a breach of contract has been determined to exist. The parties expressly agree that the price for the Products and the services was determined in consideration of the limitation on damages set forth herein and such limitation has been specifically bargained for and constitutes an agreed allocation of risk which shall survive the determination of any court of competent jurisdiction that any remedy herein fails of its essential purpose.

Limitation of Damages

In no event shall Nexen be liable for any consequential, indirect, incidental, or special damages of any nature whatsoever, including without limitation, lost profits arising from the sale or use of the Products.

Warranty Claim Procedures

To make a claim under this warranty, the claimant must give written notice of the alleged defect to whom the Product was purchased from and deliver the Product to same within one year of the date on which the alleged defect first became apparent.

nexen®

Nexen Group, Inc.
560 Oak Grove Parkway
Vadnais Heights, MN 55127

800.843.7445
Fax: 651.286.1099
www.nexengroup.com

ISO 9001 Certified